

# USER MANUAL

---

  
**CRACKAMITE**  
Mix it, Fill it, Crack it



## Welcome to the Silent Revolution

CRACKAMITE®, a Non-Explosive Expansive Silent Cracking Agent, is a highly expansive powder composition for stone breaking, granite and marble quarrying, concrete cutting and demolition.

---

Ahuja Corporation Pvt. Ltd.

**ahuja**  
group

## **DISCLAIMER**

The purpose of this document by Ahuja Corporation Pvt. Ltd. - Product Crackamite® is to provide information about the company and its products and services. Ahuja Corporation Pvt. Ltd. has made reasonable efforts to ensure the accuracy of the information provided in this document. However, to due to the possibility data errors, changes to source material made since the last update, or other human or mechanical errors, the information contained in this document should not be deemed reliable for legal purposes. Whilst every effort has been made to ensure complete accuracy, Ahuja Corporation Pvt. Ltd. does not accept any responsibility whatsoever for any errors in this information or for any errors that may result from using them. Our product catalogues, datasheets, usage manuals, its publishers, its staff, and all persons and businesses affiliated with this document are not liable for any damages resulting from use of this document. The technical information in all datasheets and articles are to the best of our knowledge at the time of publication of these datasheets and articles, and are based upon our own experience and in-house database. However, the document's information is not warranted or guaranteed to be accurate and is provided on an "as is" basis. This information is constantly being upgraded and/or changed as part of continuous improvement plans. Please contact Ahuja Corporation Pvt. Ltd. at [support@ahujagroup.in](mailto:support@ahujagroup.in) to verify the accuracy of the information

# Contents

<b>What is Crackamite? .....</b>	<b>5</b>
<b>Where can Crackamite be used?.....</b>	<b>7</b>
Applications of Crackamite .....	7
Application Areas .....	7
<b>Why Use Crackamite? .....</b>	<b>11</b>
Features of Crackamite .....	11
Advantages of Crackamite .....	11
Crackamite is the most suitable solution .....	12
Comparison Of Demolition Methods .....	13
Advantages in comparison to explosives .....	14
Advantages in comparison to mechanical breaking .....	14
<b>How Does Crackamite Work? .....</b>	<b>15</b>
Fracture Mechanism of Crackamite .....	15
Establishing Free Surfaces .....	16
Factors Affecting the Expansive Stress of Crackamite .....	17
<b>How to use Crackamite .....</b>	<b>19</b>
Crackamite .....	19
Temperature Estimation .....	19
Hole Design .....	20
Pre-drilling Holes.....	23
Mixing .....	24
Hole Filling .....	25
Cracking .....	27
Storage & Precautions .....	29
<b>Hole Design for Rocks .....</b>	<b>34</b>
General Concepts for Breaking of Boulders .....	34
Underground Excavation .....	34
Splitting of Large Boulders .....	35
Cutting Into Slabs .....	35

Breaking of Virgin Rock .....	36
Trenching And Tunnelling .....	36
<b>Hole Design for Concrete .....</b>	<b>38</b>
General Concepts for Breaking of Concrete .....	38
Reinforced Concrete .....	38
Thin Concrete.....	39
Mass Concrete .....	41
Pile Foundation .....	41
Thick Wall.....	42
Pier / Bridge / Foundation.....	43
Zone Demolition .....	44
Delayed Filling.....	45
<b>FAQ.....</b>	<b>48</b>
<b>About Us .....</b>	<b>50</b>
Customer delight is our moto .....	50
Our ideas are beyond their limits.....	50
Quality Beyond Compare .....	51
Customer Delight is Our Moto .....	51

# What is Crackamite?

## A NON-EXPLOSIVE SOUNDLESS DEMOLITION AGENT

Crackamite is a soundless, non-explosive demolition agent providing a safe and tremor-free breaking up of rock, stone and concrete without the need for special preconditions or infrastructure. Crackamite is quite different from ordinary demolition agents such as explosives and other dangerous materials. It does not cause any explosion, noise, ground vibration, gas, dust or any other environmental pollution when used properly.



- ☑ Non-toxic powder of oxides of calcium, silicon and aluminium.
- ☑ No explosion, noise, vibration, gas, dust or any other pollution
- ☑ Develops tremendous expansive pressure within a few hours
- ☑ Easy to use without special requirements or licensing
- ☑ Provides highly targeted splitting and demolition
- ☑ Suitable for all kinds of rocks, stones, boulders and concrete.

Crackamite is a non-toxic powder consisting of oxides of calcium, silicon and aluminum. The chemical composition of Crackamite is a powder consisting of an inorganic compound made mainly of a special kind of silicate and an organic compound. Crackamite does not contain any harmful components.

Crackamite provides the most technically suitable and cost-effective solution in restricted demolition of rock and concrete structures where nearby structures must be protected from shock waves generated by explosives. After a reaction time of just a few hours, Crackamite develops a huge expansion pressure which soon becomes so high that it splits apart every kind of hard rock and concrete.

Crackamite develops tremendous expansive pressure in a few hours for easy and targeted cracking and demolition of rock, stone and concrete



Explosives are expensive due to long operating times, special transport, storage and handling precautions, and the need to comply with public safety regulations. As requirements for demolishing rock and reinforced concrete in construction increase in tight quarters, the use of explosives and explosive agents is becoming more restricted as far as safety and environmental pollution problems are concerned. Crackamite is the perfect solution. Marble, granite, limestone, plain concrete, reinforced concrete, boulders, and ledge are fractured overnight without noise, vibration, or flying debris.



# Where can Crackamite be used?

CRACKAMITE CAN BE USED ON ANY TYPE OF STONE FORMATION, CONCRETE, REINFORCED CONCRETE OR TILED STRUCTURE

## Applications of Crackamite

- ☑ Industry Sectors
- ☑ Demolition Contractors
- ☑ Road Construction
- ☑ Tunnelling Work
- ☑ Blasting Contractors
- ☑ Do-it-yourself Enthusiasts
- ☑ Stone and rock Quarries
- ☑ Agriculturalists and Farmers
- ☑ Marble, Granite, Limestone Mines
- ☑ Civil Engineering
- ☑ Foundation Engineering
- ☑ Mining Companies



## Application Areas

- ☑ Quarrying of marble, granite, limestone, sandstone, etc.
- ☑ Stone cutting and splitting for sizing
- ☑ Stone, boulders and rock removal
- ☑ Levelling rock substrate for road works
- ☑ Excavating trenches for pipe-laying
- ☑ Underground excavations in rocky strata
- ☑ Demolition of concrete or reinforced concrete objects
- ☑ Demolition of foundations
- ☑ Demolition of tiled and refractory structures
- ☑ Demolition of breakwaters or jetties
- ☑ Demolition of concrete, concrete poles, towers, walls, etc.

### **Crackamite is technically suitable and cost-effective**

Crackamite provides the most technically suitable and cost-effective solution in:

- Restricted demolition of stone and concrete structures where nearby structures must be protected from vibration generated by explosions
- Pre-splitting of stone formations, to create isolated blocks that can then be more easily demolished and removed
- Cutting blocks of marble, stone and granite more economically than that of the traditional wire saw method
- Excavations and demolition of stone or concrete structures where the use of explosives would be expensive due to long operating times, special transport, storage, handling precautions and the need to comply with public safety regulations.



### Special Benefits of Crackamite for Mining Industry

- ❖ Production can be significantly increased using Crackamite for mining operations, as there are no safety problems associated with blasting
- ❖ The dimensions of the block can be easily controlled with Crackamite as its extremely targeted and there is no waste to deal with.
- ❖ Mining operations can be conducted in a working environment unhampered by flying debris or dust. No post blasting cleaning up is required.
- ❖ Efforts are concentrated on exploiting the ore or precious stone-bearing reef - a factor that is most important in marginal situations.
- ❖ Crackamite is ideal for the mining of emeralds and other precious and semi-precious stones, as it does not destroy or break the brittle material, it only cracks the surrounding stones.
- ❖ Shelf life of Crackamite is long depending on the storage conditions, i.e., humidity, ambient temperature etc. thus obviating problems associated with out-of-date material, as may be the case with explosives and detonator fuse.
- ❖ Hoisting operations can be minimized when using Crackamite, significantly reducing electricity and maintenance costs.
- ❖ Mines employing only Crackamite do not need to evacuate personnel from the quarry before





blasting. Labour can therefore be more productively and cost-effectively employed, thus safeguarding jobs and time.

- ❖ No machine or equipment is damaged because of the blasting and resultant flying debris.
- ❖ Crackamite saves industries costs by providing all-round saving, particularly in the areas of labour, winching, electricity maintenance and cleaning.
- ❖ Mine safety is promoted because there is no danger of underground fire caused by explosives or igniter cord. There is no post-blast caused by misfires. Mine safety is further enhanced since the disturbance of the surrounding rock is minimal as there is no concussion or vibration and there are no blasting accidents.
- ❖ Heavily dangerous areas are mineable utilizing Crackamite due to its inherent capabilities.

### **Special Benefits of Crackamite for Demolition Work**

- ❖ Eliminates noise, flying debris and vibration caused by blasting or heavy mechanical equipment and machines
- ❖ Increases the productivity of mechanical demolition equipment since it does the major breaking up work
- ❖ Cracking and splitting can be extremely controlled and targeted including sequential breaking
- ❖ Minimizes risk in high exposure situations such as rock or concrete excavation adjacent to rail lines, fibre optic cables, pipelines, etc.
- ❖ Works well in underwater area in difficult conditions for demolition work
- ❖ Saves time in shutdown conditions where work has to be stopped for certain periods
- ❖ Eases the removal where impact force is limited by specifications
- ❖ Makes removal in confined spaces easier
- ❖ Accelerates removal time once fracturing occurs
- ❖ Requires no licensing or storage security



## Comparison of Crackamite with other demolition methods

Type of Demolition Agent	Demolition/ Breaking Power	Conditions created at the work site					Protection needed at job site*	Economy*	
		Noise	Ground Vibration	Dust/ Gas	Flying particles	Safety			
<b>Explosives (Dynamite)</b>	Very High	Very High	Very High	Very High	Very High	Very High	Very Low	Very High	Very High
<b>Explosives (Concrete Cracker)</b>	High	High	High	Very High	High	Low	Very High	High	High
<b>Rock breaker</b>	Low	High	Low	Low	Very Low	High	Low	Low	Low
<b>Hydraulic Splitter</b>	High	Low	Low	Almost Nil	Almost Nil	High	Low	Low	Very Low
<b>Crackamite</b>	High	Nil	Nil	Almost Nil	Nil	Very High	Almost Nil	High	High



# Why Use Crackamite?

CRACKAMITE HAS UNLIMITED ADVANTAGES OVER OTHER METHODS IN ALMOST EVERY INDUSTRY

## Features of Crackamite

Crackamite mixed with an appropriate quantity of water and poured into cylindrical holes drilled in rock or concrete, creates a **tremendous expansive pressure of 11 MT/m<sup>2</sup>**, cracking the substrate to be demolished or split.

- It is a non-toxic powder made of oxides of calcium, silicon and aluminium.
- It causes no explosion, noise, vibration, gas, dust or any other pollution
- It develops tremendous expansive pressure within a few hours of pouring
- It is easy to use and has no special requirements or licensing
- It provides highly targeted splitting and demolition
- It is suitable for all kinds of rocks, stones, boulders and concrete.

## Advantages of Crackamite

Crackamite can be used in an unlimited range of applications. It's particularly useful for breaking, cutting, splitting or demolishing stones, concrete and reinforced concrete. Endless benefits of Crackamite can be listed against explosives and other methods of breaking, cutting, splitting or demolishing.

### i. Crackamite is a safe substance

Crackamite is not controlled by any legal regulation as is the case in explosives and other explosive agents, etc. **It is non-explosive**; therefore, supervision of trained personnel is not essential. Crackamite has no special storage requirements or precautions if kept in a dry place. Crackamite is not sensitive to electrical discharge or currents. Demolition can be easily and safely performed anywhere, outdoors or indoors and even underwater.

### ii. Crackamite is a soundless cracking agent

Unlike the common methods of demolition by explosives or breaking equipment, Crackamite does not create any noise, vibration, flying debris, dust or gas. Crackamite quietly and gradually demolishes

rock or concrete with its expansive stress caused by hydration reactions. Rocks and reinforced concrete can thus be demolished safely without environmental pollution. Furthermore, Crackamite's expansive stress continues even after crack initiation, hence, the crack opening distance becomes wider as time passes.

### **iii. Crackamite is easy to handle**

No lid or cap is necessary after Crackamite is poured into a hole of rock or reinforced concrete, nor is any tamping required as with explosives. Crackamite exerts its strength in a short time. Due to Crackamite's strong adhesion and frictional resistance to inner surface of the hole, spurs due to heat-generation (blown-out shot) do not occur when used within limit parameters. The expansive stress along the hole depth is almost constant except near the entrance of the hole. Generally, the expansive stress loss from the hole entrance has little effect on the demolition work when hole depth is long.

### **iv. Crackamite is very easy to use**

Just mix Crackamite demolition powder with water, pour the mixture into holes, and it expands to crack. Neither capping with mortar, sand, etc. nor tamping with a bar is necessary after Crackamite mixture is poured into drilled holes in rock or concrete. Using Crackamite does not require a special license unlike explosives, explosive agents, etc. **It is environment friendly.** It releases no toxic or harmful substances of any kind.

### **v. Crackamite creates tremendous expansive stress**

Generally, the compressive fracture stress of rocks is 500 to 2500 T/m<sup>2</sup> and that of concrete 300 to 500 T/m<sup>2</sup>. However, the tensile fracture stress is very small, it ranges from 40 to 70 T/m<sup>2</sup> in concrete. Since demolition by using Crackamite is based on a fracture due to a tensile stress, all kinds of rocks and concrete can be cracked and broken by using Crackamite when appropriate holes are properly drilled.

### **vi. Crackamite is high-efficiency and systematic**

Crackamite makes it very easy to control the shape of to-be-cracked objects after being broken according to requirements; it can be demolished or can remain unharmed. Crackamite cracks reinforced concrete, rock, limestone, granite and marble safely and quietly. Being a non-explosive material, it works without noise, vibration, dust, toxic gases and flying rock. Cracked rock or concrete can then easily be broken with breakers remarkably reducing time and cost required for breaking. Crackamite can demolish rock or concrete systematically, and also demolition work in water is possible.

## **Crackamite is the most suitable solution**

Crackamite provides the most technically suitable and cost-effective solution in:



- Restricted demolition of stone and concrete structures where nearby structures must be protected from vibration generated by explosions
- Pre-splitting of stone formations, to create isolated blocks that can then be more easily demolished and removed
- Cutting blocks of marble, stone and granite more economically than that of the traditional wire saw method
- Excavations and demolition of stone or concrete structures where the use of explosives would be expensive due to long operating times, special transport, storage, handling precautions and the need to comply with public safety regulations.

## Comparison Of Demolition Methods

There are many superior points in the demolition work performed by Crackamite as compared to other demolition methods. It has also been proven to be more economical. The outline of this comparison indicated in the table1 below:

### Comparison of Crackamite with other demolition methods

Type of Demolition Agent	Demolition/ Breaking Power	Conditions created at the work site					Protection needed at job site*	Economy*
		Noise	Ground Vibration	Dust/ Gas	Flying particles	Safety		
Explosives (Dynamite)	Very High	Very High	Very High	Very High	Very High	Very Low	Very High	Very High
Explosives (Concrete Cracker)	High	High	High	Very High	High	Low	Very High	High
Rock breaker	Low	High	Low	Low	Very Low	High	Low	Low
Hydraulic Splitter	High	Low	Low	Almost Nil	Almost Nil	High	Low	Very Low
Crackamite	High	Nil	Nil	Almost Nil	Nil	Very High	Almost Nil	High

## Advantages in comparison to explosives

- Completely safe and extremely simple to use
- No license requirements
- Little to no training required
- No restrictive storage regulations
- No transport regulations
- Not rated as dangerous goods
- No debris, flying fragments, dust or gas
- No wastage in mining due to breakage
- Optimal splitting, loosening or breaking up
- Suitable for both indoor and outdoor use
- Highly predictable and targeted demolition
- No authorisations required and no obligation to register work
- Causes no pollution thus to pollution control needed
- Explosion protection equipment not required
- Completely tremor-free and silent
- No wiring, no ignition or additional equipment



## Advantages in comparison to mechanical breaking

- Completely safe and extremely simple to use
- Huge savings in time and costs
- No noise pollution, completely silent
- Can be easily used at night
- Work-load reduction and less worker requirements
- Optimal splitting, loosening or breaking up
- No large machines are required
- Can be used in restricted areas and tight spaces
- Precise cost calculations and consumption
- Causes no pollution thus to pollution control needed



# How Does Crackamite Work?

CRACKAMITE MIXED WITH WATER CREATES TREMENDOUS EXPANSIVE PRESSURE TO CRACK THE SURROUNDING MATERIAL

When Crackamite is mixed with an appropriate quantity of water and poured into cylindrical holes drilled in rock or concrete, it hardens and creates an **tremendous expansive pressure of 11 MT/m<sup>2</sup>**. Crackamite cracks the substrate to be demolished which can then be easily removed with a pick breaker, pneumatic breaker, excavator, etc.

Crackamite develops a very high expansive capability at a consistent volume exceeding 122 Mpa (**11,200 T/m<sup>2</sup>**) more than enough to break up any materials to be split or demolished. The tensile strength for most rock is less than 5 - 25 Mpa (500 - 2500 T/m<sup>2</sup> or 50 - 250 kg/cm<sup>2</sup>) while reinforced concrete breaks at 3 - 5 Mpa (30 - 50 kg/cm<sup>2</sup> or 300 - 500 T/m<sup>2</sup>).

Temperature 35°C  
Time 16hrs.  
Water Ratio 30%  
CRACKAMITE CM - A

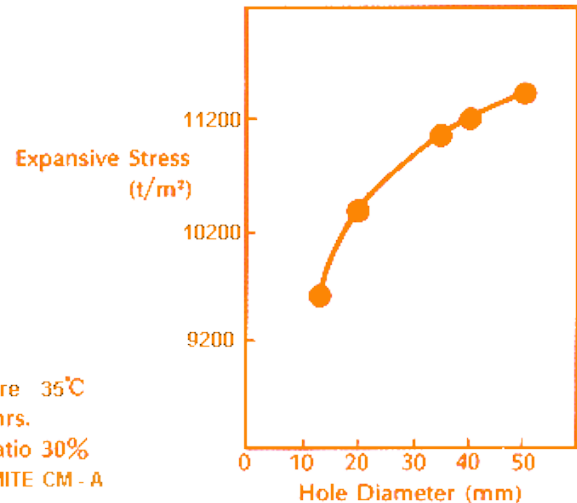

## Fracture Mechanism of Crackamite

After Crackamite is poured into holes drilled in rocks or concrete, the expansive stress gradually increases with time, and reaches to more than 11,000 T/m<sup>2</sup> at room temperature after 24 hours. As Crackamite generates its expansive stress, the material to be cracked undergoes a process of (1) crack initiation, (2) crack propagation, (3) the increase of crack width. Therefore, this fracture mechanism is distinguished from a breakage by blasting.

The mechanism by the expansive stress of Crackamite is shown in *Fig. 1*. Cracks initiate from an inner surface of the hole, being caused by tensile stress at a right angle with the compressive stress that occurs by the expansive stress of Crackamite. The expansive stress of Crackamite continues even after the appearance of cracks, the cracks propagate and also new cracks initiate during the process. Usually, for a single hole, 2 - 4 cracks initiate and propagate. When a free surface exists, the crack, as



shown in *Fig. 2*, is pushed apart mainly by the shear stress, and a secondary crack also arises from the bottom of the hole running toward the free surface.

When multiple numbers of holes are filled with Crackamite, that are properly adjacent to each other, the cracks from the hole propagate to connect with the neighbouring holes, as shown in *Fig. 3*. It is therefore possible to determine the directions of the cracks as planned by appropriately arranging the hole spacing and its depth and its inclination.

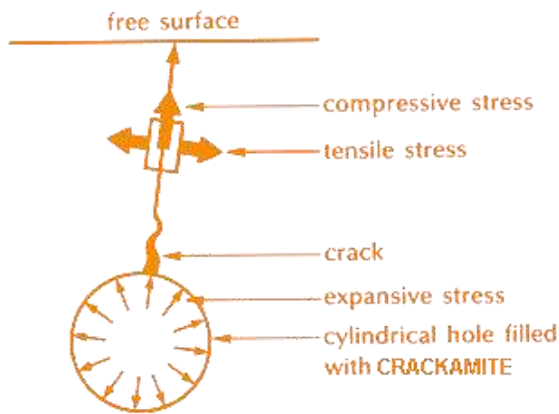

**Fig. 1** - Fracture mechanism due to expansive stress generated by Crackamite

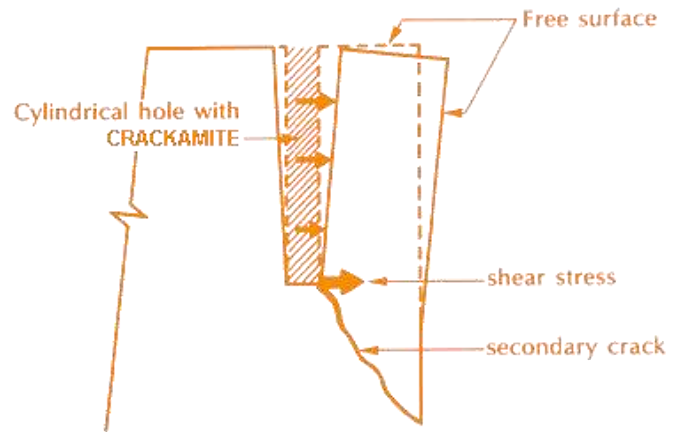

**Fig. 2** - Sectional-view of the crack formation in material with two free surfaces

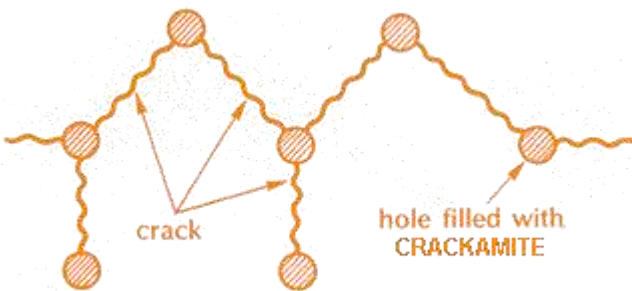

**Fig. 3** - View of crack propagation between adjacent holes due to Crackamite

## Establishing Free Surfaces

In the case of trenching, shafting or tunnelling, if all holes are drilled vertically and filled with Crackamite, the crack width cannot increase but horizontal cracks initiate. Therefore, in order to obtain two free surfaces, inclined holes or pre-splitting must be required.



## Factors Affecting the Expansive Stress of Crackamite

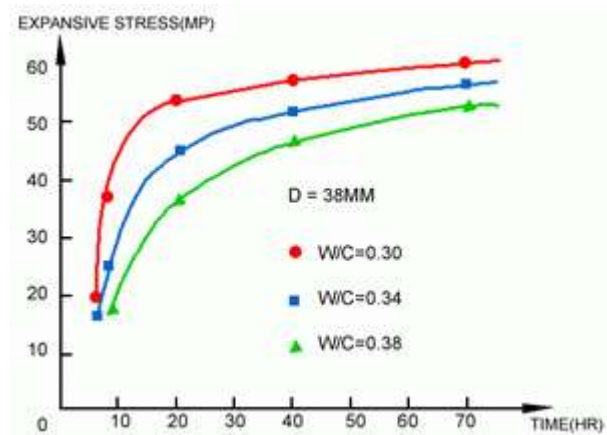
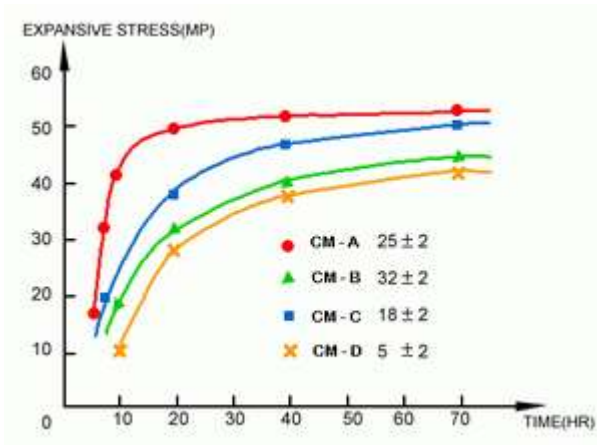

a) **Time:** The expansive stress developed by Crackamite reach a maximum value at about 24 hours of reaction. However it still keeps increasing slightly even afterwards.

b) **Water Ratio:** The expansive pressure of Crackamite decreases as the water to Crackamite powder ratio increases. The optimum ratio is **0.30**

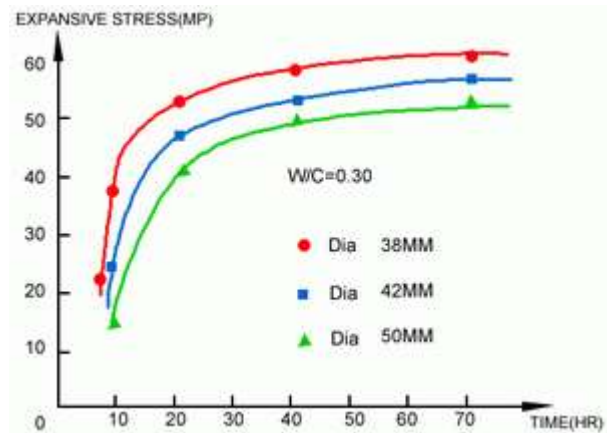
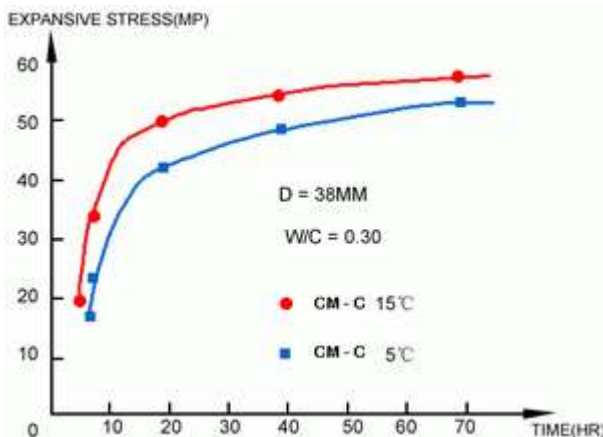

c) **Temperature:** The expansive capabilities of Crackamite increases with increase in ambient operating temperature upto the maximum operating temperature.

d) **Hole Diameter:** The expansive power of Crackamite decreases with increase in the diameter of pre-drilled hole above the optimal value

1. The expansive stress can be increased to more than 11,200 T/m<sup>2</sup>. (Fig. 1 & 3)
2. The larger the hole diameter is, the greater the expansive stress becomes. (Fig. 2)
3. There is little change in the expansive stress when the water ratio is in the neighbourhood of approximately 30%. However, the stress is decreased as the water ratio is increased or decreased.

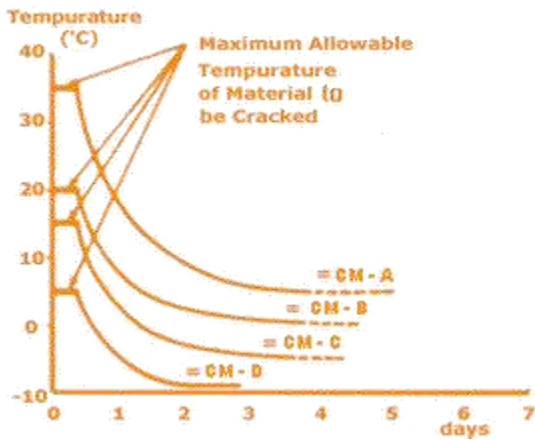

**Fig. 1** - Time required for expansive stress to reach 11,200 T/m<sup>2</sup> and temperature

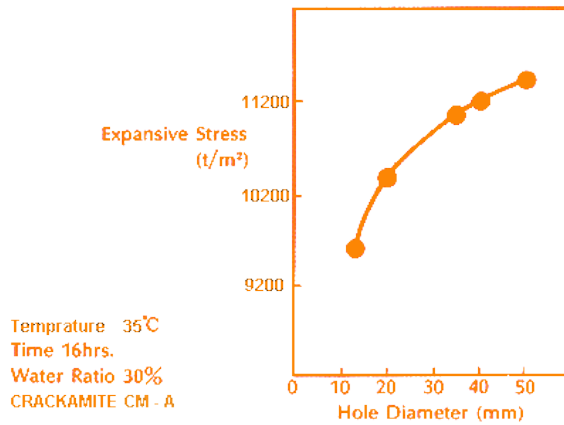

**Fig. 2** - The relation between the expansive stress generated and hole diameter

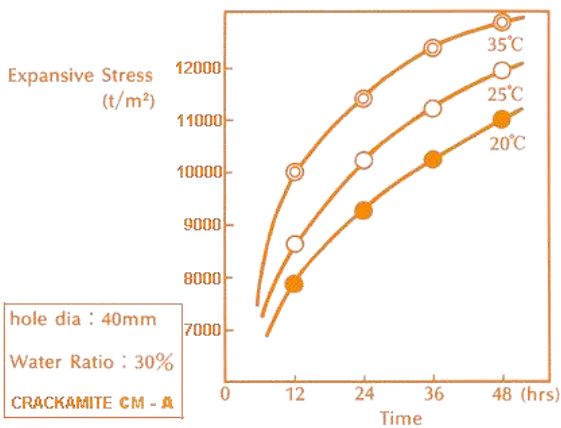

**Fig. 3** - Changes in the expansive stress over time and at different temperatures

# How to use Crackamite

IT IS AS EASY AS MIX IT, FILL IT, CRACK IT

Boulder Breaking, Rock Splitting and Cracking, Marble, Limestone and Granite Mining as well as Concrete Demolition has never been easier, safer and environmentally friendly than with Crackamite Non-Explosive Demolition Powder. Crackamite is a chemical mixture powder with super expansive strength when it is mixed with water. When this Crackamite mixture is filled into drilled holes, according to the appropriate hole design, Crackamite breaks apart concrete and cracks and splits rocks and boulders safely and quietly.



## Crackamite

**Type:** Universal type for all temperatures.

**Packing:** 5 Kg in one plastic bag, 4 bags in one carton, and 50 boxes on one wooden pallet.

**Form:** Powder and cartridge available.

**Reaction Time Control:** Special Inhibitor available on request to control reaction time for special applications.

## Temperature Estimation

As shown in the figure on the right, place a thermometer in the bottom of the hole and leave it in place for 2-3 minutes. Then quickly pull out the thermometer and take a reading. Avoid taking temperature right after drilling since the temperature of the hole is higher because of friction heat. The temperature of the rock or concrete being broken is important first step.

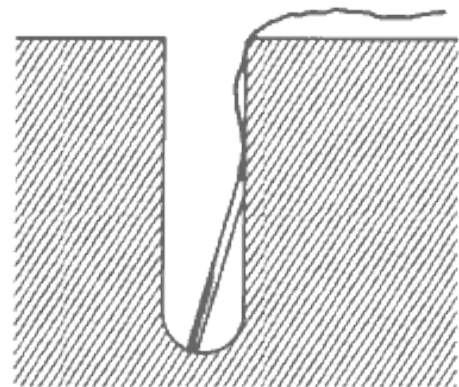

## Hole Design

Crackamite's effectiveness depends on the placement, diameter and depth of the holes drilled in the material. The drilling must be done in relation to the job to be performed. The design for breaking should be done according to the properties of rocks, joint, volume to be removed, secondary breaking, and work period, etc.

### Effective Hole Design for Crackamite

The hole design refers to the hole diameter and hole spacing/distance. For hole diameter between 30 to 50 mm, the hole spacing (distance between holes) should be in accordance with the following formula:

$$A = K \times D$$

where, **A** - hole spacing (in mm),  
**D** - hole diameter (in mm) and  
**K** - cracking coefficient.

hole spacing		cm.	20	40	60	80	100
		feet	1	2	3		
hard virgin rocks					←→		
soft virgin rocks				←→			
presplitting of the above rocks			←→				
Reinforced concrete	foundation, pillar, beam		←→				
	wall, slab		↔				

### K value of rocks and concrete

Material to be cracked	K value	Steel contained (Kg/m <sup>3</sup> )
Soft virgin rocks	10 - 16	n/a
Medium hardness virgin rocks	8 - 12	n/a
Hard virgin rocks	5 - 10	n/a
Plain concrete	10 - 16	0 - 30
Reinforced concrete	8 - 10	30 - 60
	6 - 8	60 - 100



**K Value changes with the geometry and shape of rock or concrete**

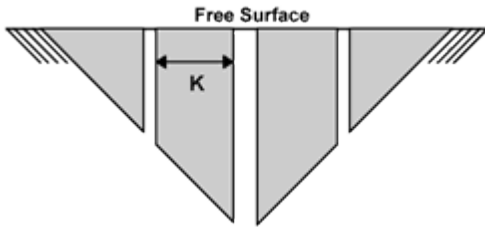

Lesser the free surface, smaller the K value

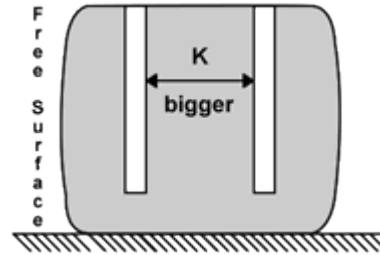

Greater the free surface, larger the K value

**Cracking design reference chart**

Material to be cracked	Hole design parameters				Crackamite Consumption (Kg/m <sup>3</sup> )
	Diameter D (mm)	Hole Spacing A (cm)	Row Spacing R (cm)	Hole Depth H (%)	
Soft stone	35 - 40	40 - 100	(0.6 - 0.9) A	100%	5 - 10
Medium hard rock	38 - 42	30 - 40	(0.6 - 0.9) A	105%	12 - 22
Hard granite	38 - 42	25 - 40	30 - 80	105%	18 - 25
Rock cutting	30 - 40	20 - 40	(0.6 - 0.9) A	75%	12 - 18
Plain concrete	38 - 42	20 - 30	(0.6 - 0.9) A	80% - 85%	12 - 18
Reinforced concrete	38 - 50	15 - 30	(0.6 - 0.9) A	90% - 95%	18 - 25

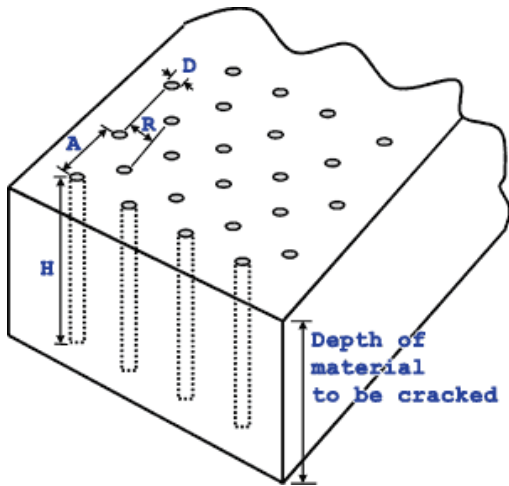

**Note:** Before experimenting with a test break, reference should be made to 'Hole Design for Rock' or 'Hole Design for Concrete' to assist in your special needs for successfully planning a break design.

### Estimating Crackamite Quantity Required

Once the hole design is fixed, it is simple to figure out how much Crackamite you need. Crackamite consumption is calculated as the sum of the depths of all boreholes times the corresponding factor of the used borehole diameter. The formula is:

$$C = \text{Kg/m}^3 \times \text{Number of Holes} \times \text{Depth of Holes}$$

**General coverage:** Normally one 44 lb (20 kilograms) box of Crackamite can fill up to 35 linear feet (about 10 meters) of 1½ inches (3.8 centimetres) diameter holes. You might not have to fill up every hole depending on application.

**As a thumb rule:** Each 5 kilo bag will fill 8 linear feet of 1½" hole or 11 feet of 1¼" hole.

### Kg/m<sup>3</sup> values for different hole sizes and depth of 1 meter

Hole Diameter	30 mm	32 mm	34 mm	36 mm	38 mm	40 mm	42 mm	44 mm	46 mm	48 mm	50 mm
Crackamite (Kg/m <sup>3</sup> )	1.2	1.3	1.5	1.7	1.9	2.1	2.3	2.5	2.8	3.0	3.2
Hole Depth	One Meter										
Note:	You may get 3% to 6% less yield due to field conditions.										

## Pre-drilling Holes

Crackamite's effectiveness depends on the placement, diameter and depth of the holes drilled in the material. To determine the right combination of hole size and spacing, first make a reference hole design using the parameters from the hole design sections, then drill several holes of different diameter at different burden and spacing. Now check the break conditions of each of them and then decide hole diameter, depth, burden and spacing.

### Drilling

- i. **Drilling machine:** Use electrical drill, rock drill or crawler drill.
- ii. **Drilling direction:** It is preferable to drill holes vertically, but in case of a wall or pillar of reinforced concrete where vertical drilling is difficult, an inclined hole may be drilled. Since a greater effect is achieved with a deeper hole, in case of a thin material, consideration should be given so as to get a long hole depth by drilling it obliquely, if necessary. Horizontal holes can have the same spacing as with vertical holes.
- iii. **Hole diameter and hole spacing:** The breaking plan of the hole design sections should serve as a guideline in making this decision. In general, the preferable hole diameter is from 40 to 50 mm.

### Hole Depth

1. **Maximum Hole Depth** is 10 feet. (3.05 meter)
2. **Minimum Hole Depth** is 4 times hole diameter; for example 5" with 1¼" hole, 6" with 1½". Holes shallower than 4 times diameter are likely to blow out.
3. **Recommended Hole Depth:** In reinforced concrete, drill 90% to 95% of its depth. In a ledge, drill as deep as you want to remove. In boulders, drill 2/3<sup>rd</sup> to 3/4<sup>th</sup> of the rock's thickness. In soft rock, like Marble, hole depth is 100%. In middle or high hardness rock, like granite, hole depth is 105%.

### Hole Pattern

1. Holes must be drilled so as to allow a free face for the Crackamite to push towards. For example, drilling at a 45° angle in the flat surface of a ledge will push it upwards, but drilling straight down might not allow the pressure to go anywhere.
2. To demolish a slab without pushing out the walls, which surround it, drill a cone shaped pattern at the centre and fill these holes first. The cone will pop upwards and create a free face.

3. Hole pattern depends on tensile strength of what is being broken, amount of rebar, if any, and the size of the pieces you want when you're done. This can often be determined by experiment; a good starting point is to space holes one foot apart, in rows, one and a half feet apart. In non-reinforced concrete, holes may be spaced as far apart as 30 cm.
4. Hole pattern also depends on how fast you need results. More holes spaced closer together will give faster cracking time and smaller pieces, but will cost more in terms of labour and Crackamite.
5. Boulders are much easier to break than reinforced concrete or ledge, and drill holes can be spaced further apart, especially if breaking speed is not critical.
6. Empty holes can also be used to direct cracks - they cost less than filled holes. This will save money compared to filling all the holes, but will slow down the breaking time.

## Mixing

Crackamite is a powder that must be thoroughly mixed with clean water before use, in a ratio of 30 % of the overall weight (1.5 litres for each 5 kg package). Gradually add the powder to water, stirring all the time to obtain a smooth, lump-free mortar.

### Mixing Equipment

Mix Crackamite with water, one bag at a time, by hand or, preferably, with a mechanical mixer.

Prepare the following equipment:

1. **Container:** A metal or plastic bucket or clean can of 10 - 20 litres capacity.
2. **Mixer:** Preferably a handheld mechanical mixer.
3. **Water Measurement:** Fixed volume bottle, beaker or measuring cylinder.
4. **Protection:** Rubber gloves and boots, and safety glasses.

### Mixing Method

Pour approximately 1.5 litre (0.4 U.S. gallon) of water into container. Add one bag of Crackamite gradually and mix well until it has a good fluidity.

When viscosity of the mixture of Crackamite and water is too high to pour into the hole, add a little water to get a good fluidity. Do not exceed 34% of water ratio (1.7 litre; 0.45 U.S. gallon per 5 kg; 11 lb. of Crackamite). The mixing time by hand-mixer is about 2 - 3 minutes. It is recommended that a mechanical mixer be used on large volume jobs. When mixing by hands, wear rubber gloves.

### Mixing Water

- i. Use clean water that is not contaminated with oil, organic substances, etc.

- ii. Use the proper temperature of water for each grade of Crackamite
- iii. Water at a temperature below 15°C (59°F) must be used when the average atmospheric temperature is more than 45°C for Crackamite CM - H.
- iv. The cooler the water is, the longer Crackamite mixture will remain fluid.

### Standard Quantity

The quantity of Crackamite to be used for cracking differs with the hole spaces and diameters. In the table below, the relation between the quantity of Crackamite used and the hole diameters is indicated for the hole of 1 m depth, where Crackamite is mixed at a water ratio of 30%.

#### Kg/m values for different hole sizes

<b>Hole Diameter</b>	30 mm	32 mm	34 mm	36 mm	38 mm	40 mm	42 mm	44 mm	46 mm	48 mm	50 mm
<b>Crackamite (Kg/m<sup>3</sup>)</b>	1.2	1.3	1.5	1.7	1.9	2.1	2.3	2.5	2.8	3.0	3.2
<b>Hole Depth</b>	One Meter										
<b>Note:</b>	You may get 3% to 6% less yield due to field conditions.										

### Audit Checklist Before Mixing

- Are people on the work site wearing safety equipment?
- What is the rock/concrete temperature?
- What is the water temperature?
- What is the drill hole diameter?
- Have you calculated the extra water required if rock/concrete temperature is above 22°C?
- Are you going to cover the filled holes with a tarpaulin sheet?
- How much time does it take to fill the hole?

### Hole Filling

Immediately after mixing the Crackamite powder into proper slurry, pre-drilled holes need to be filled with the Crackamite paste.



## Filling of the holes with Crackamite

Please observe the following points while filling the pre-drilled holes with Crackamite:

- Crackamite should be poured into holes within 10 minutes after mixing with water. The Crackamite mixture may lose fluidity within 10 minutes of mixing and will become difficult to pour. Once its fluidity is gone, it should not be diluted by re-mixing with water, as its strength is reduced. Longer mixing time will cause blow-outs.
- Crackamite is best filled using a bucket with spout or funnel. For a horizontal hole use a grout pump. Drill horizontal holes with some slope to help in filling.
- Crackamite must be poured into every hole up to the brim.
- For a horizontal hole, the hole can be easily plugged with Crackamite as it reaches clay like consistency as it starts setting.

## Use of polythene sack in hole

- If there is water in the hole, place a thin polythene sack equal to the hole diameter into the hole, insert a wooden rod into the bag and then fill Crackamite into the sack. Crackamite in the sack will displace the water in the hole. There is no change in the cracking strength by the use of this kind of sack.
- When there are many joints or large voids/holes in the material to be cracked or when Crackamite leaks from the hole, use the sack method.
- When a lot of the water in the Crackamite slurry is being absorbed into the material being cracked (for instance, a dry concrete), use the sack method or alternatively, spray water. However, in cold temperature, avoid pouring water as it may freeze in the hole.
- When the material to be cracked is immersed in water, use the sack method. Use a bucket or pump when filling the sack and then seal the sack from the top to avoid Crackamite slurry dilution. If there is no flow of water around the mouth of the holes, Crackamite may be directly poured into the holes using the pump. This should gently displace the water in the hole.

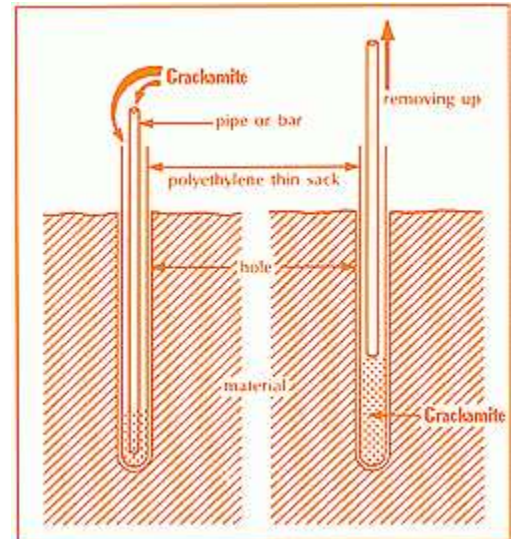

## After Treatment

- DO NOT leave excess Crackamite slurry in the bucket as blow-outs may occur.

2. Tamping with mortar or sand is not required after filling with Crackamite slurry. It is also not necessary to put any kind of restrictive cap. Just leave it as it is and wait until cracks initiate. Covering the filled hole with tarpaulin is desirable to avoid dilution of Crackamite slurry from external water source until cracking starts.
3. Spraying the surface with water, after the cracks initiate, tends to increase the width of cracks and speeds up the cracking process.

## Cracking

### Crack Formation

Upon filling of the pre-drilled holes with the mixed Crackamite slurry, reaction immediately starts to occur in the Crackamite. Upon reacting, the Crackamite mortar starts hardening and expanding causing the material to develop cracks. The cracks generally appear within 3 to 20 hours after filling, depending on the temperature. These cracks spread further and become wider with time.

### Time Required for Crack Formation

Reaction starts as soon as Crackamite is mixed with water causing it to expand and harden. When the Crackamite expansive mortar is packed into a hole in stone or concrete, it swells and exerts pressure on the hole-walls and thus fractures it.

The cracks appear within 45 minutes after filling, depending on weather, rock or concrete temperature. The cracks become wider with time. The ambient temperature in the material being cracked determines the reaction speed. The higher the temperature, the shorter the reaction time.

The time required for full crack formation in material at 30°C is about 6 - 8 hours. The lower the temperature, the longer the crack formation takes. The crack width for rock continues to increase with time and can become 10 - 30 mm (3/8" - 1 1/8") after several days, depending on free surface available. It is best to wait until Crackamite has worked to full depth before removing the rock, as premature removal at the first sign of a crack can hamper the leverage effect of Crackamite.

Some points to remember after filling, while waiting for the cracks to appear:

1. Tamping with mortar or sand is not required after filling Crackamite. It is also not necessary to put any restrictive cap. Just leave it as it is and wait until cracks initiate.
2. Covering the filled hole with tarpaulin is desirable to avoid dilution of Crackamite from external water source until cracking starts.
3. Spraying the surface with water, after the cracks initiate, tends to increase the width of cracks and speeds up the cracking process.

4. If only small cracks are found, you can pour more water into the crack line for further expansion.

### Controlling Expansive Strength and Reaction Time

For Crackamite, the higher the temperature, the quicker is the reaction. There are two ways to control the cracking agent's reaction time. For universal type, reaction inhibitors of 20 gram per bag are available for each 5 kg package in carton. 20 gm inhibitor can be added into water first and then the powder can be mixed to avoid the possibility of blow out shots. For quantity details refer to the following table:

#### Quantity if inhibitor required

Site Temperature	Qty of Bag (20 g)
5 °C	None
15 °C	1 per 3 bag
25 °C	2 per 3 bag
35 °C	1 per bag

### Cutting and Secondary Breaking

When the cracking gap is around 3 - 5 cm, you can carry out the further demolition work. After cracks initiate, secondary breaking is carried out with a hand-breaker, a pick-hammer, a giant hydraulic breaker, a ripper, etc. It is best to wait until the Crackamite has worked to full depth before removing rock or concrete since premature removal at the first sign of a crack hampers the leverage effect of Crackamite.

#### Type of secondary breaking required

Type of breaking by Crackamite	Secondary breaking required
Fragmentation	Hammer, Power shovel
Crack Formation	Hand breaker, Power shovel, Hydraulic breaker
Pre-splitting	Combination of mechanical breaker or dynamite

### **Please Note:**

- a. Be sure to wear PROTECTIVE GLASSES when secondary breaking is carried out.
- b. The crack width for rock or concrete continues to increase with time and can become 10-30 mm (3/8"-1 1/8") after several days, depending on free surfaces available.

## **Storage & Precautions**

### **Packaging and Storage**

Crackamite is packed in 4 anti-moisture bags of 5 kg each and then placed in a waterproof carton with a total weight of approximately 20 kg.

1. Although Crackamite is packed in anti-moisture bags, long storage may cause deterioration of its working ingredients. Therefore, store in a dry place and use it as soon as possible.
2. When storing, do not place the bags of Crackamite directly on the floor. Put them on a pallet and keep in a dry warehouse. Crackamite stored in this manner, can be effectively used for 1 year.
3. Crackamite should be unpacked properly in a low moisture environment before use.
4. When storing the portion of Crackamite remaining after use, remove air out of the bag, seal it and use as soon as possible. However, as it may get exposed to moisture, there is a risk of Crackamite losing its effectiveness once the bag has been opened.
5. If you receive damaged bags of Crackamite, they may not work due to chance of moisture absorption.

### **Recommendations For Crackamite Usage**

1. Use a pair of safety glasses, rubber gloves and dust mask when working.
2. DO NOT look at any hole closely or directly within 2 - 3 hours after filling, as there may be splatter or a blowout.
3. Store mixed or dry Crackamite properly.
4. Choose the correct grade according to the working conditions.

### **Usage tips to achieve better results:**

1. Mix well and pour, while agitating the slurry, to make sure that no air gaps are left in the hole.

2. Fill the hole almost to the top, leaving at least ½ inch before reaching the top.
3. In summer, the best time to use Crackamite is early morning or evening when temperature of the material is low. High material temperature might cause *blowouts*.
4. In summer, cover the holes to avoid direct sunlight, by using a tarpaulin or wet hay.
5. When the ambient temperature is high, put some ice into the water, and then mix with Crackamite.
6. Depending on the material to be cracked, Crackamite may be mixed with more water to lower the costs.
7. For better results, it is important to note both air and material temperature. Material temperature is the temperature inside the rock or concrete which can be different from the air temperature. **DO NOT GUESS!** Tie a string on the thermometer and lower it into the drill hole.
8. In winter, mix 1% calcium chloride with Crackamite.
9. If Crackamite has completely dried into powder and there are no cracks, then pour additional water onto Crackamite filled holes.
10. Never fill glass or metal containers with Crackamite or any container that widens towards the bottom.
11. Never pump Crackamite with pressure.
12. Mixing by hand lengthens mixing time, and is more likely to result in a blowout.
13. When rock or concrete temperature is above 23°C, add approximately 150 ml of extra water per 5 Kg bag.
14. Holes have to be cleared after hole drilling
15. For marble the hole depth has to be 95% - 98%
16. To make the splitting faster, a greater number of holes are to be made closer to each other.
17. For 5 kg of Crackamite 1.5 ltr clean cold water has to be added.
18. The mixture has to be continuously stirred to avoid lumps
19. The mixture has to be poured within 10 minutes of preparation
20. After filling the holes, cover the same with tarpaulin to avoid direct sunlight
21. Cold Water may be added to the holes after 2 hours to speed up the process.



22. For 5 kg powder add 1.5-ltr water, the total volume will become 2.68 ltr. This is sufficient to fill 11 running feet of 32 mm holes with the mixture.
23. Shelf life of Crackamite is one year - Two years depending on the storage conditions, i.e. humidity, ambient temperature etc.
24. The best results can be achieved with experiments on the actual work site, as the hardness, density and other parameters of stone / concrete to be cracked and working conditions vary from time to time and place to place.

### **Safety Precautions**

1. Do not use Crackamite for purposes than cracking rocks or concrete.
2. Crackamite is a highly alkaline product. The pH reaches 13 after contact with water and can cause severe irritation to mucous membranes, especially eyes. Rinse with large amounts of water any portion of the skin that comes in contact with Crackamite. Consult a doctor immediately.
3. Wear safety glasses, rubber gloves and a helmet during Crackamite handling, mixing and filling. Wear a dust mask when using Crackamite in poorly ventilated areas such as tunnels or mines.
4. Do not pour and leave Crackamite in bottles or cans to avoid shattering of the bottle or can.
5. Do not look directly into any holes for at least 6 hours after pouring. Crackamite may splatter or blow out of the hole due to heat generation when temperature of material to be broken is over the temperatures found in the temperature chart. Do not get your face close to or stand near filled holes for at least 3 hours after completion of filling.
6. Shelter the holes from rain or sunlight only with a tarpaulin sheet.
7. Do not use hot water.
8. Do not mix over one bag (5 kg, 11 b.) of Crackamite with water at a time.
9. Use the proper grade of Crackamite.
10. Keep out of reach of pets and children

### **Notes On Crackamite Working**

1. The most cost-effective demolition technique for ledge demolition is a combination of Crackamite (to produce cracks) and a hydraulic hammer or a jackhammer. Drill holes can be spaced out further in this case.

2. The best way to demolish underwater rocks or concrete is to build a cofferdam and pump out the area. Crackamite hardens in fifteen to twenty minutes, and after that the area can be flooded again.
3. Crackamite must be used in holes; pouring it into existing cracks in the rock will not work.
4. Safety glasses must be worn at all times by everyone in the area. Hard hats and steel-toed boots are a good idea on any construction or demolition site.
5. When using the usable temperature chart, bear in mind that the actual drill hole temperature may be much higher than the surrounding air temperature if it is in the sun or affected by nearby heat from machinery or from drilling the holes.
6. Cold temperature, hard rock, or holes spaced too far apart can lengthen breaking times. If it did not crack overnight - wait a while before assuming failure. Crackamite continues to increase pressure for 24 - 28 hours
7. When mixed, if Crackamite begins to steam in the bucket, add ½ gallon or more of water, stir, and throw it away. You've allowed too much time to pass from beginning to mix.
8. If filled holes start to smoke or steam, that is a sign they may be about to blowout. Immediately clear the area of people. The vapours are only steam, and are not hazardous or toxic in any way.

## **Blowouts - Causes and Precautions**

### **What can cause a blowout?**

1. Using too large a hole diameter.
2. Using too warm mix water. See the temperature chart.
3. Using too little water, especially when rock or concrete is above 23 °C.
4. Too much time passing between beginning to mix and filling holes.
5. Mixing by hand.
6. Guessing at drill hole temperature instead of measuring it.
7. Guessing at water temperature instead of measuring it.
8. Holes that are too shallow. Depth MUST be 4 times the diameter or more.
9. Allowing the powder to become too hot before mixing with water.
10. A "know-it-all" attitude that causes some people to ignore this manual instead of reading it thoroughly, cover to cover.
11. Holes drilled closer than 10 " apart in soft rock or concrete, in hot weather
12. Drill hole diameter 1½" is the best to work with
13. Blowouts will usually not occur more than 3 hours after filling holes.



## How to prevent blow outs

1. Use the right grade of Crackamite for the temperature range, especially with rock or concrete.
2. Keep every source of heat away from Crackamite
3. Do not store Crackamite in direct sunlight or near a source of heat. Cool Crackamite before use.
4. Do not mix Crackamite into small or narrow-mouthed plastic cans or bowls. Instead use a metal bucket.
5. Cool every tool you are going to use before mixing.
6. Use the indicated water amount (11.5 litre for each bag of 5 kg of product)
7. Do not use hot water to mix Crackamite
8. Mix manually no more than two bags (10 kg) for each batch at a time.
9. Mix thoroughly, avoiding lump formation for at least 2 - 3 minutes.
10. If the mortar becomes slightly stiff, add a little more water to achieve the right fluidity.
11. Pour all freshly mixed mortar into holes within 5 minutes of mixing.
12. Do not overfill the holes
13. Do not tamp filled holes with bars or similar tools
14. Do not plug holes with hard or setting materials after filling.
15. Do not pour Crackamite mortar into glass bottles or similar containers; the pressure will shatter the glass. Dispose off unused mortar only after substantial dilution with water on an open surface.

# Hole Design for Rocks

Crackamite's effectiveness depends on the placement, diameter and depth of the holes drilled in the material

## General Concepts for Breaking of Boulders

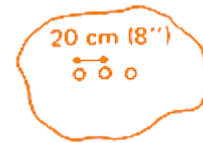
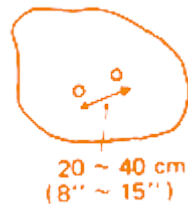
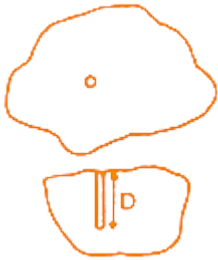

(1) Soft Rock

(Tensile Strength: <math>< 60 \text{ kg/cm}^2</math> :  
85 psi)

(2) Middle Hard Rock

(Tensile Strength: 60 - 100  
 $\text{kg/cm}^2$  : 80 - 140 psi)

(3) Hard Rock

(Tensile Strength: > 100  $\text{kg/cm}^2$   
: 140 psi)

d	38 - 44 mm
	1 1/2" - 1 3/4"
D	70 % of Height

## Underground Excavation

d	38 - 44 mm
	1 1/2" - 1 3/4"
L	30 - 60 cm
	1' - 2'
D	Shown in Figure

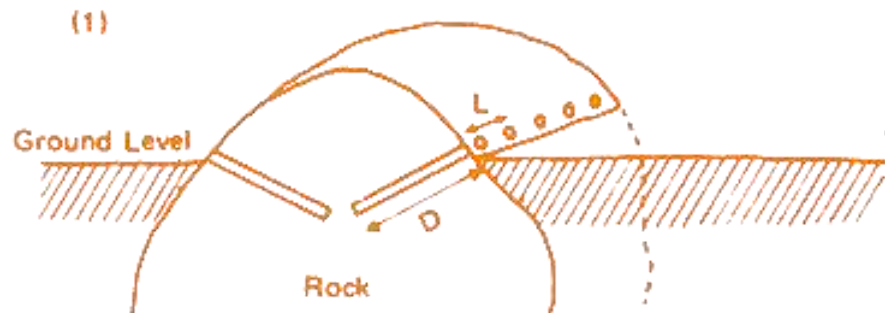

(1) Above ground boulder

d	38 - 51 mm
	1½" - 2'
L	60 - 90 cm
	2' - 3'
D	90 % of Height

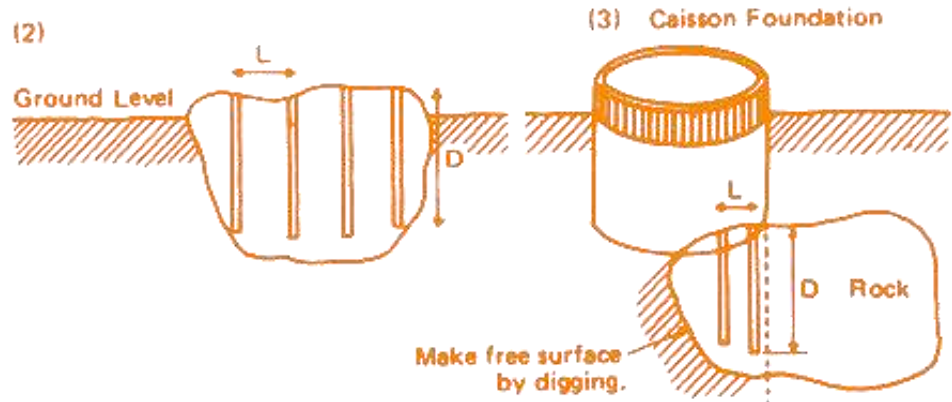

(2) Mostly below ground boulder

(3) Underground boulder

### Splitting of Large Boulders

d	32 - 35 mm	44 - 51 mm
	1¼" - 1 3/8"	1¾" - 2"
L	30 - 40 cm	60 - 90 cm
	1' - 1' 4"	2' - 3'
D	70 % of Height	

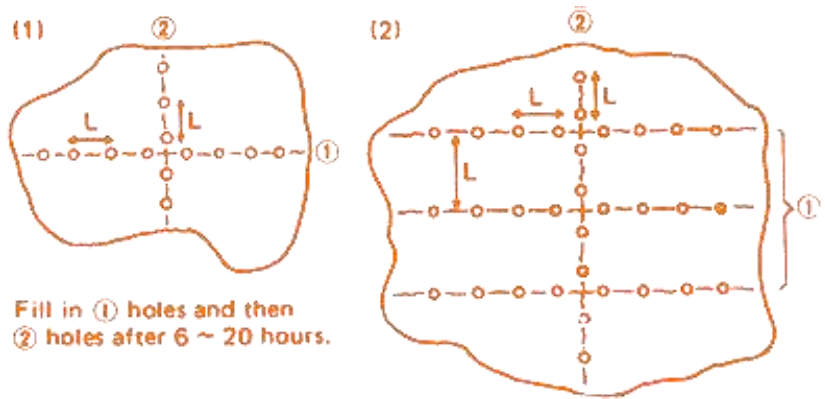

### Cutting Into Slabs

d	32 - 35 mm	44 - 51 mm
	1¼" - 1 3/8"	1¾" - 2"
L	20 - 30 cm	40 - 50 cm
	8" - 1'	1'4" - 1'8"
D	90 % of Height	

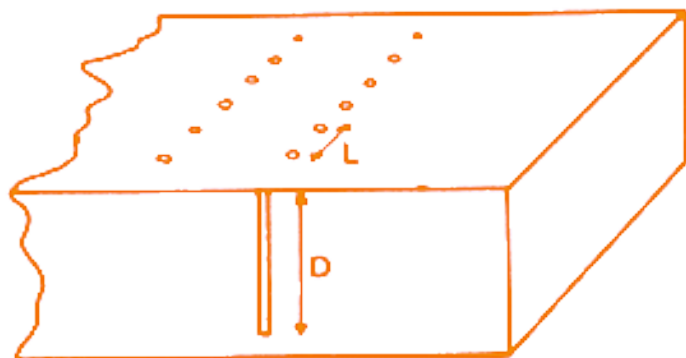



## Breaking of Virgin Rock

d	44 - 51 mm
	1¾" - 2"
L 1	30 - 40 cm
	1' - 1'4"
L 2	60 - 90 cm
	2' - 3'
D	Add 5 % of Height
	80° - 90°

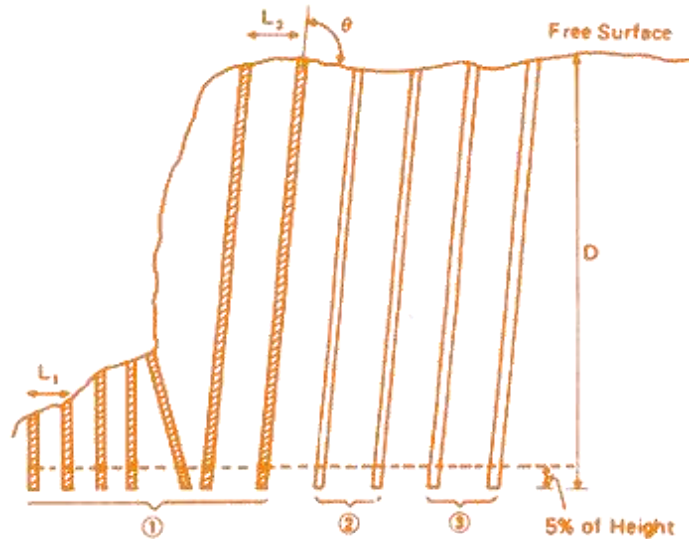

The toe should be drilled at closer hole spacing and successively broken from the front row. No drilling will cause poor breakage. The front holes (up to the sixth row) may be simultaneously filled in. It is more effective for removal to fill in one hole and then each two rows (2, 3) after a delay of 6 - 20 hours.

## Trenching And Tunnelling

d	38 - 51 mm
	1½" - 2"
L	30 - 60 cm
	1' - 2'
D	1 - 1.8 m
	3' - 6'
	45° - 60°

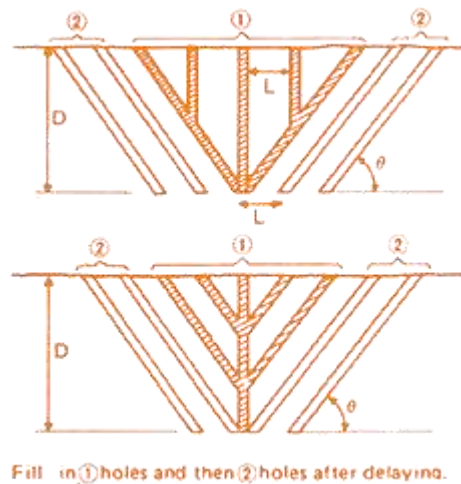

Reliever holes are necessary when trench is deep

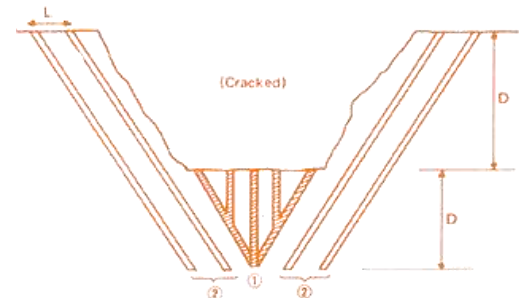

Repeat the same procedure for deeper case

d	38 - 51 mm
	1½" - 2'
L 1	40 - 60 cm
	1'4" - 2'
L 2	30 - 40 cm
	1' - 1'4"
D	1 - 1.8 m
	3' - 6'

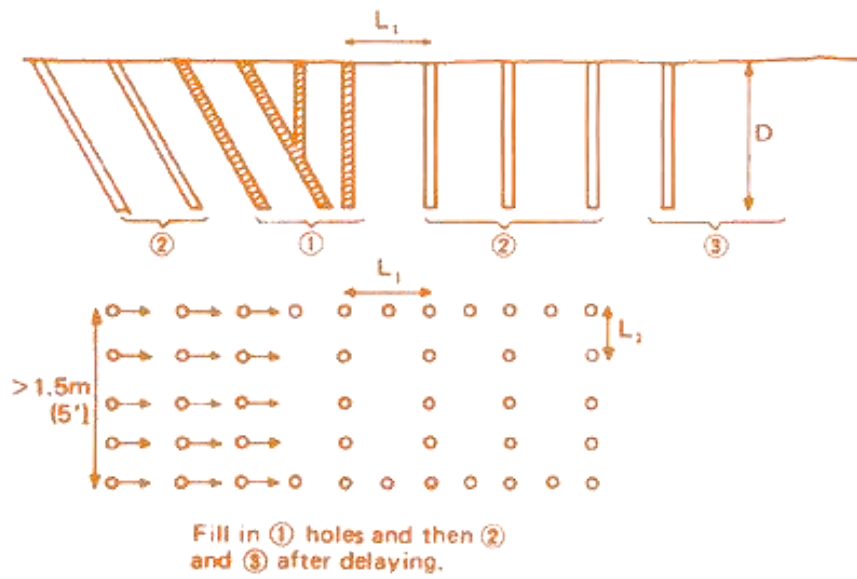

d	38 - 44 mm
	1½" - 1¾"
L	30 - 60 cm
	1' - 2'

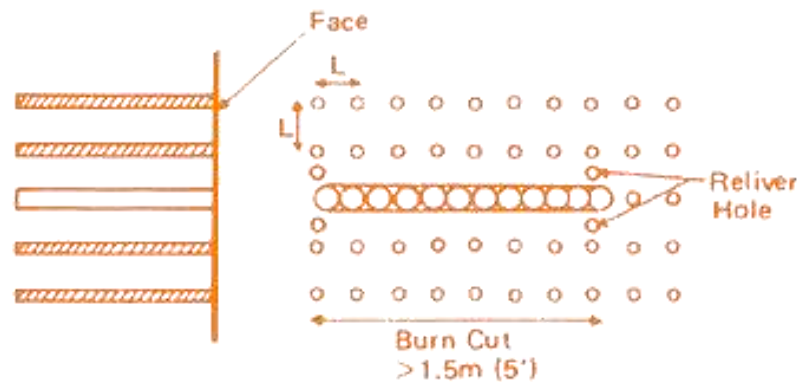

# Hole Design for Concrete

Crackamite's effectiveness depends on the placement, diameter and depth of the holes drilled in the material

## General Concepts for Breaking of Concrete

d	32 - 35 mm
	1½" - 1¾"
L	40 - 60 cm
	1' 4" - 2'
D	70% of Height

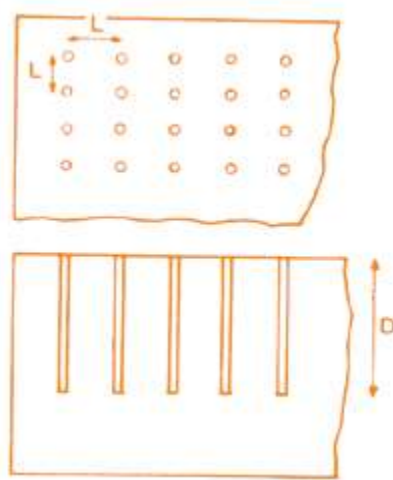

When vertical drilling is difficult, drill horizontal holes with some slope.

## Reinforced Concrete

d	35 mm	38 - 44 mm
	1 3/8"	1 ½" - 1 ¾"
L	20 - 25 cm	30 - 40 cm
	8" - 10"	1'-1'4"
D	90% of Height	

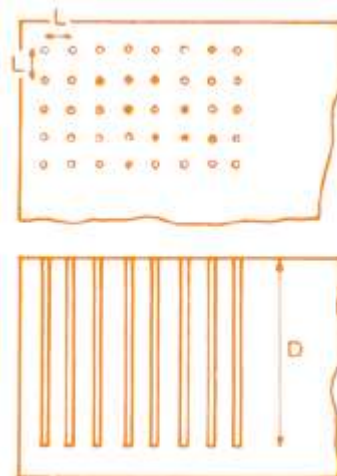

d and L depend on both quantity and shape of the reinforced steel.

## Thin Concrete

### (1) SQUARE ARRANGEMENT

d	32 - 38 mm
	1 ¼" - 1 ½"
L	25 - 30 cm
	10" - 1'
D	Almost Wall Thickness

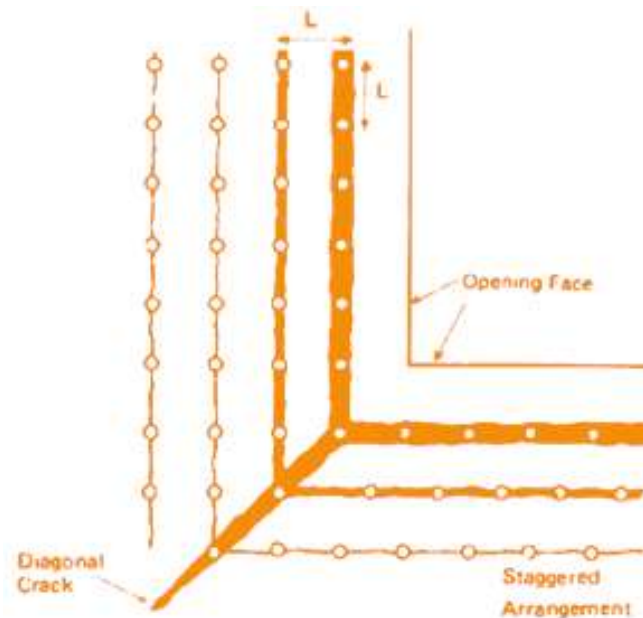

Crack width of the front row is opened much larger than that of the behind rows.

### (2) AVOIDING DIAGONAL CRACKING

d	32 - 38 mm	25 mm	32 - 38 mm
	1 ¼"-1 ½"	1"	1 ¼" - 1 ½"
L	25 - 30 cm	10 cm	10 - 15 cm
	10" - 1'	4"	4"-6"

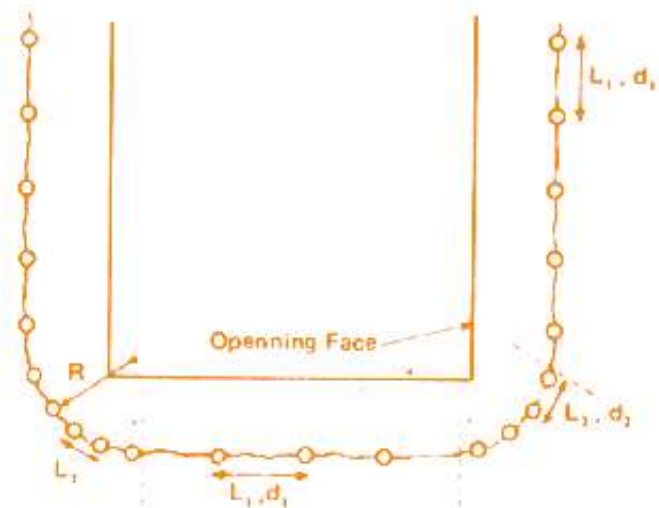

The curvature at corner (R) should be more than 15 cm (6').

**(3) SPLITTING OF WALLS**

d	38 - 44 mm
	1 ¼" - 1 ½"
L	25 - 30 cm
	10" - 1'

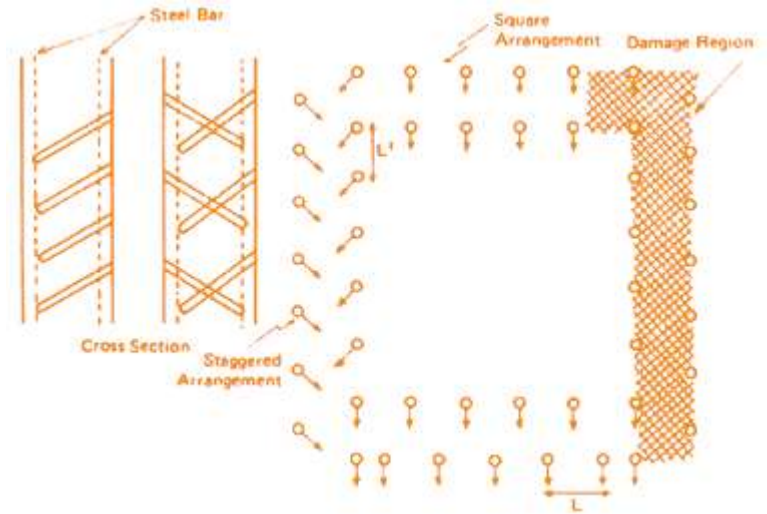

**(4) SPLITTING OF SLABS**

d	38 - 44 mm
	1 ½" - 1 ¾"
L	25 - 30 cm
	10" - 1'

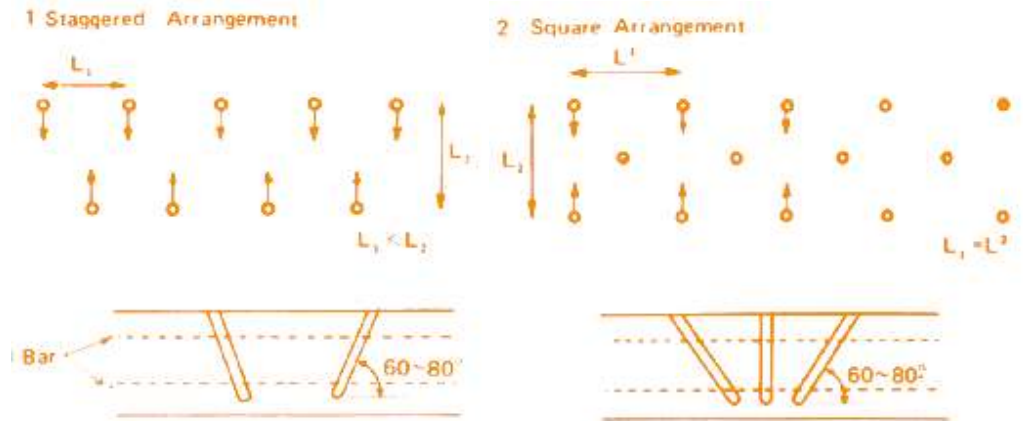

**(5) ESTABLISHING FREE SURFACES**

d	38 - 44 mm
	1 ½" - 1 ¾"
L	25 - 30 cm
	10" - 1'

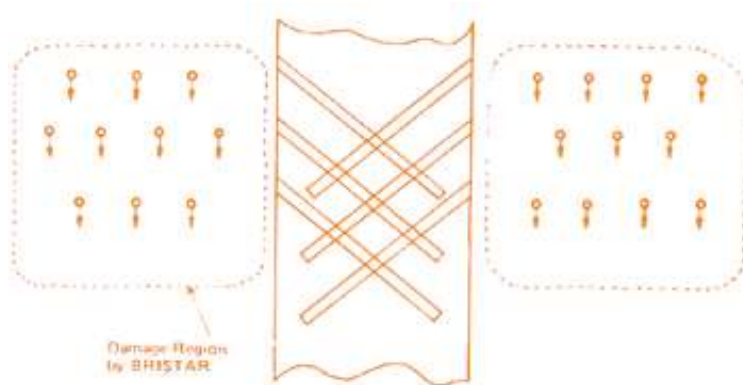

Instead of Burn Cut, cross drilling may be used to establish the free surface for wall case.



## Mass Concrete

	Concrete	Reinforced Concrete
d	38 - 51 mm	38 - 44 mm
	1 ½" - 2"	1 ½" - 1 ¾"
L	50 - 90 cm	40 - 60 cm
	1'8" - 3'	1'4" - 2'

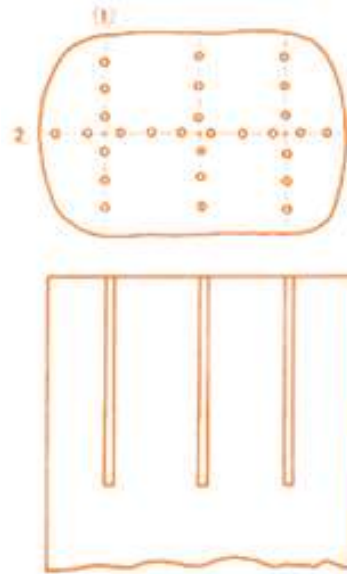

## Pile Foundation

d	38 - 44 mm
	1 ½"-1 ¾"
L <sub>1</sub>	20 cm
	8"
L <sub>2</sub>	20 - 25 cm
	8" - 10"

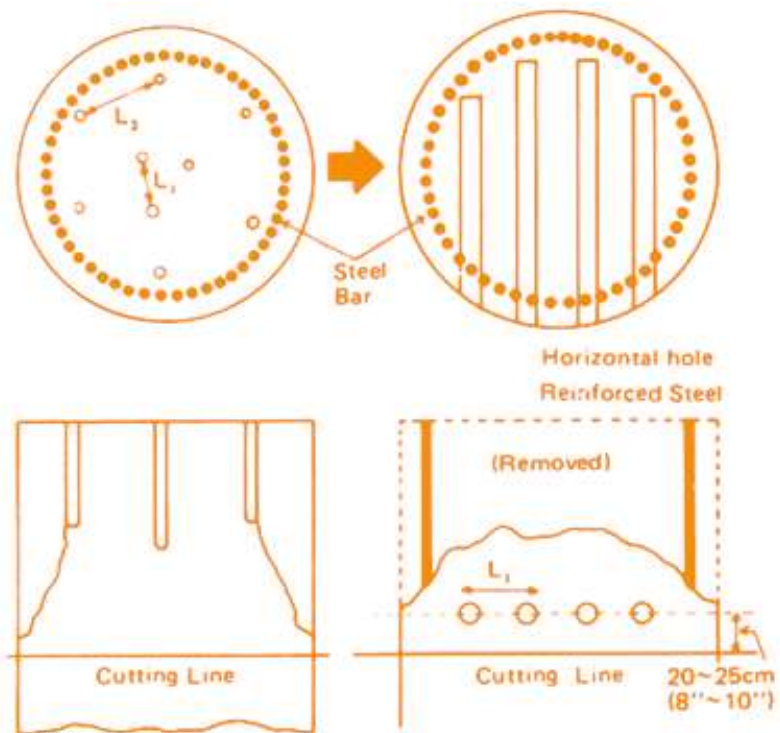

## Thick Wall

d	38 - 44 mm
	1 ½" - 1 ¾"
L	30 - 60 cm
	1' - 2'

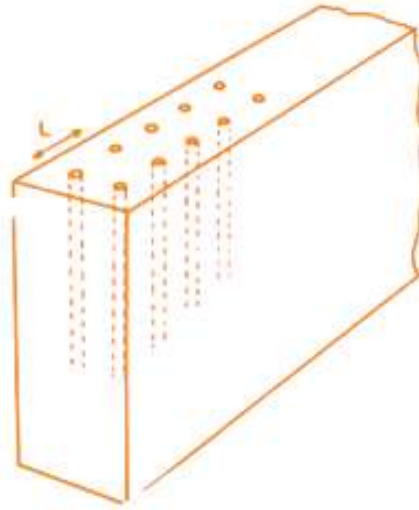

Cracks propagate along wall face

When perpendicular cracks to wall face are necessary:

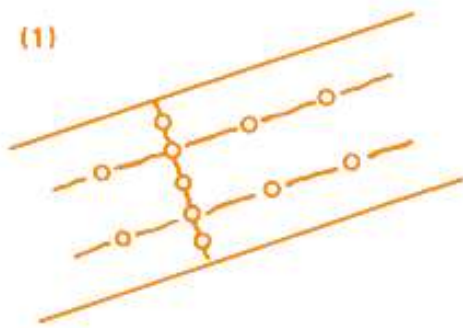

(1) Add a reliever hole.  
Spacing may be 10 cm (4') through 20 cm (8').

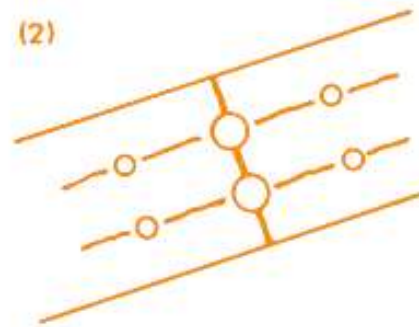

(2) Drill larger diameter holes

## Pier / Bridge / Foundation

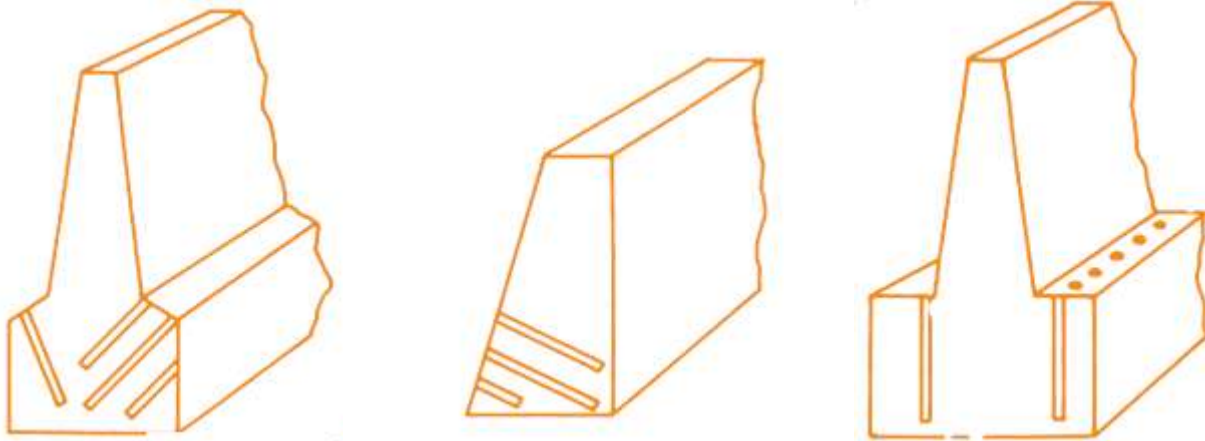

Drilling pattern depends on the shape of the structure and the site situation.

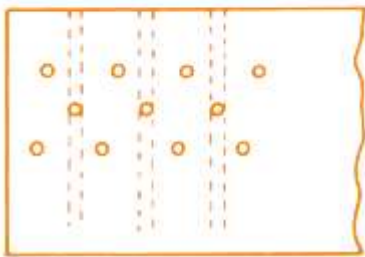

1. Making of large block; Secondary breaking with large rock breaker

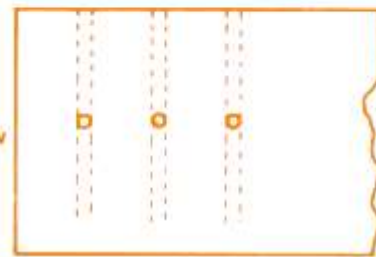
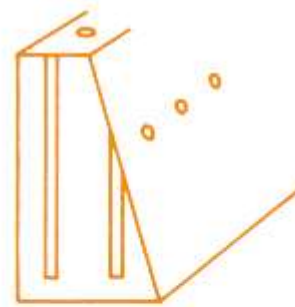

Side View

2. Making of small pieces; Drilling is only from one side.

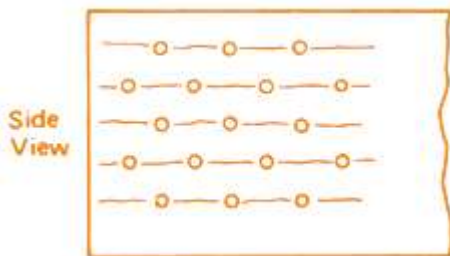

Side View

3. Wall is very high; Vertical drilling is difficult

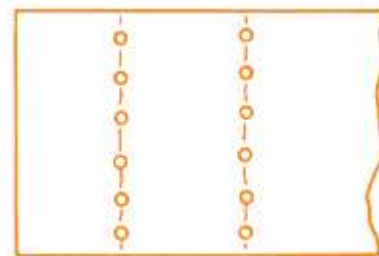

Side View

4. Foundation is thick, Secondary breaking with large rock breaker.

## Zone Demolition

### (1) STAGGERED ARRANGEMENT (PILLAR)

d	38 - 44 mm
	1 ½" - 1 ¾"
L	30 - 40 cm
	1' - 1'4"
D	90% of Width or Height

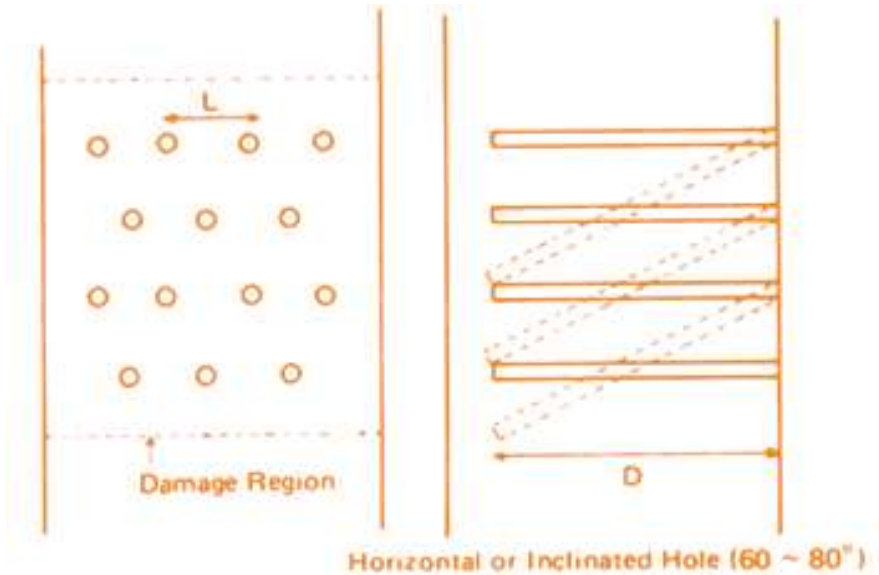

### (2) X FIGURE ARRANGEMENT (PILLAR, WALL)

d	38 - 44 mm
	1 ½" - 1 ¾"
L	30 - 40 cm
	1' - 1'4"
D	90% of Width or Height

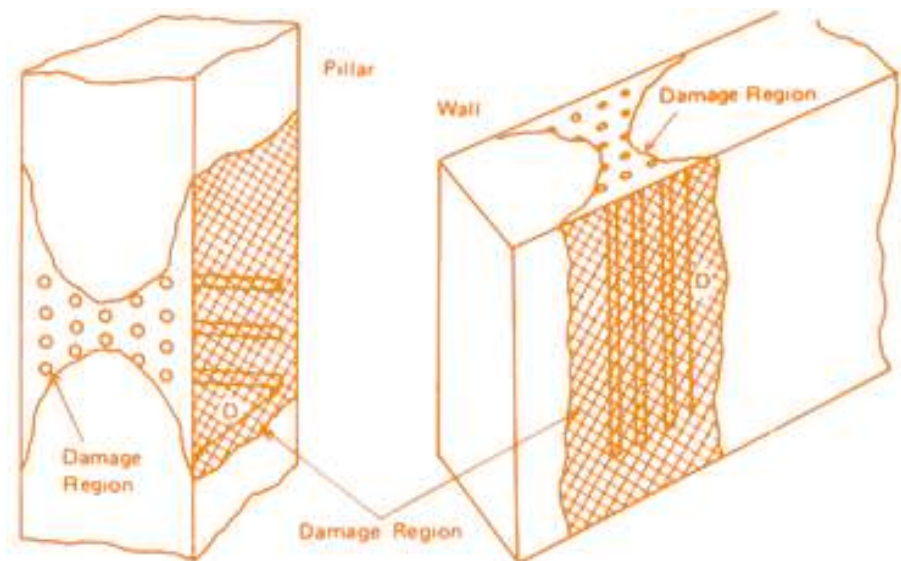

### (3) CROSS DRILLING (BEAM)

d	38 - 44 mm
	1 ½" - 1 ¾"
L	30 - 40 cm
	1' - 1'4"
D	90% of Width or Height

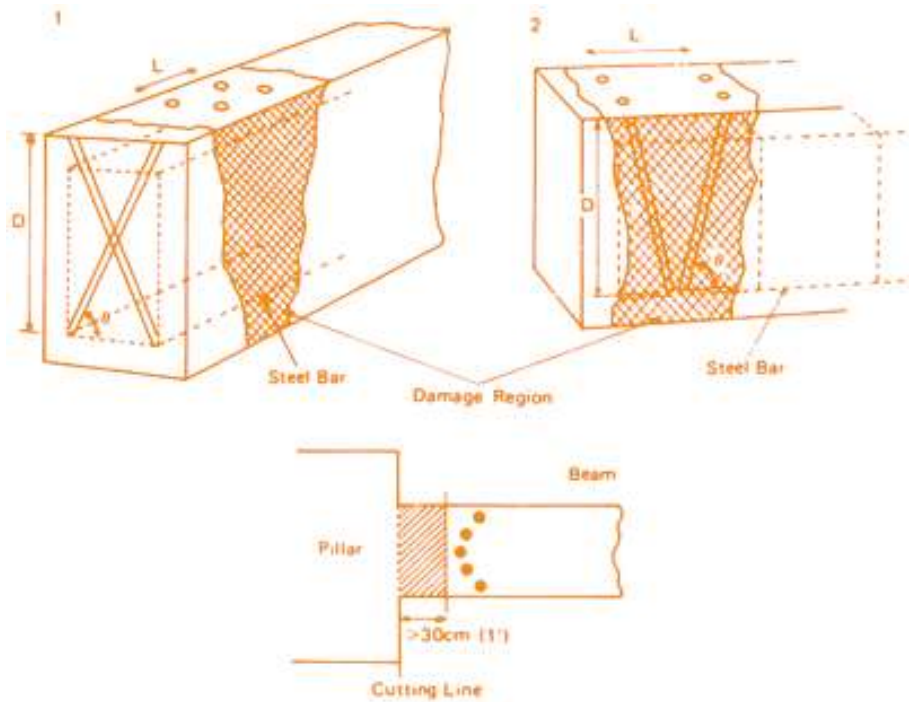

### Delayed Filling

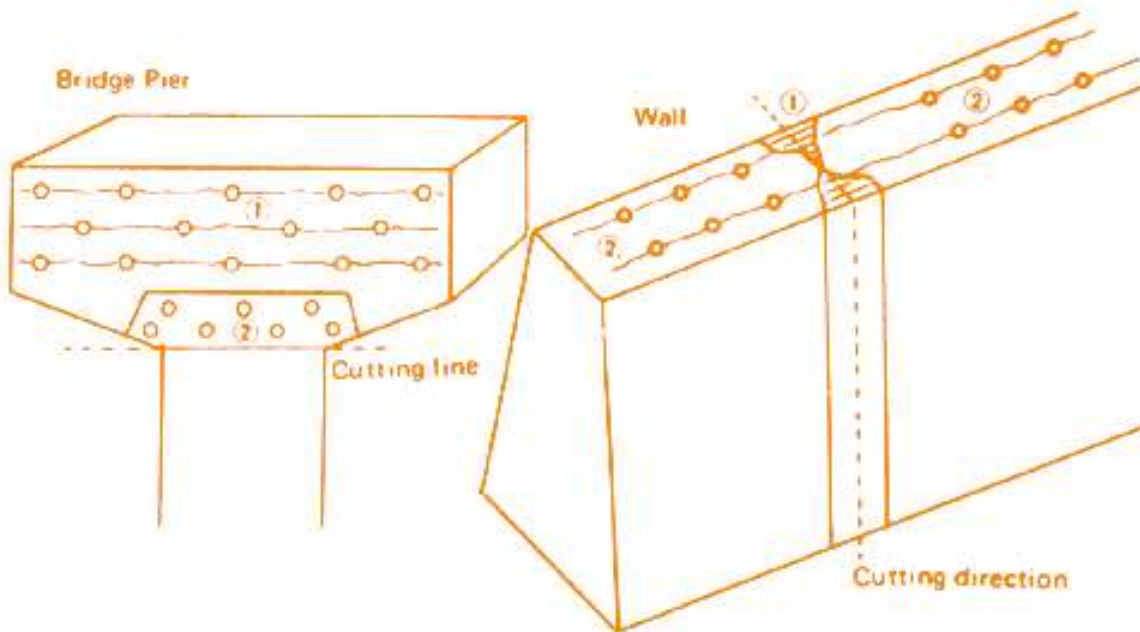

Fill in (1) holes then (2) holes after a suitable delay.

This can be applied for controlling the cracking direction (See below).

**FIGURE 1: SPLITTING OF LARGE BOULDER**

d	32 - 35 mm	44 - 51 mm
	1 ¼" - 1 3/8"	1 ¾" - 2"
L	30 - 40 cm	60 - 90 cm
	1' - 1'4"	2' - 3'
D	70% of Height	

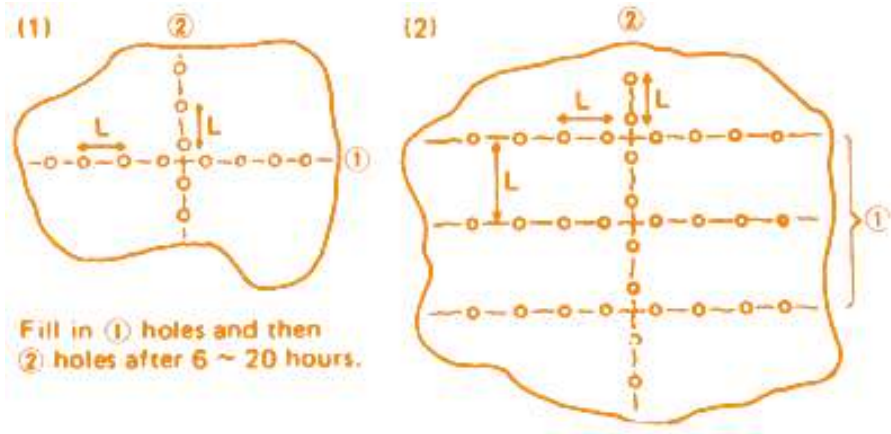

**FIGURE 2: TRENCHING AND TUNNELING OF ROCK**

d	38 - 51 mm
	1 ½" - 2"
L	30 - 60 cm
	1' - 2'
D	1 - 1.8 m
	3' - 6'
⊖	45°-60°

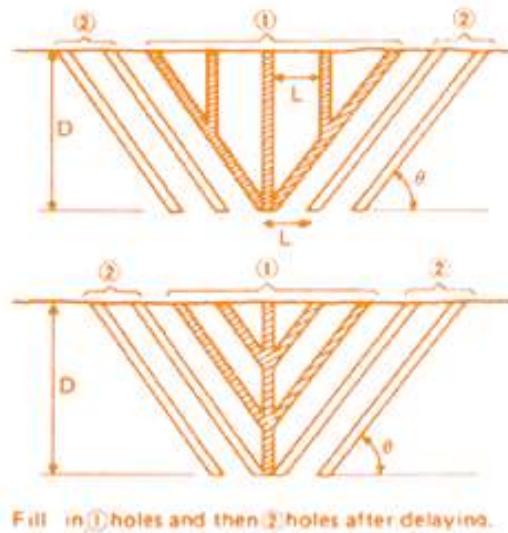

Reliever holes are necessary when trench is deep



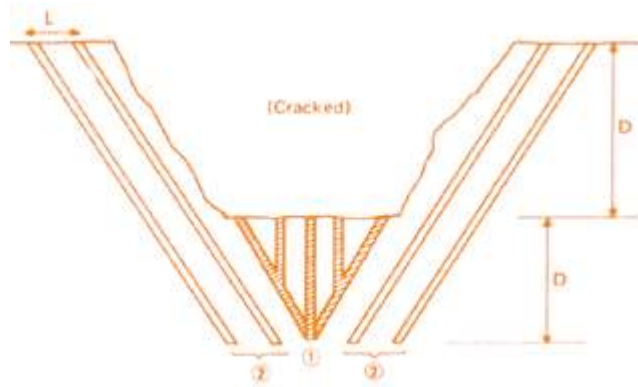

Repeat the same procedure for deeper case

**FIGURE 3:  
MASS CONCRETE**

	Concrete	Reinforced Concrete
d	38 - 51 mm	38 - 44 mm
	1 ½" - 2"	1 ½" - 1 ¾"
L	50 - 90 cm	40 - 60 cm
	1'8" - 3'	1'4" - 2'

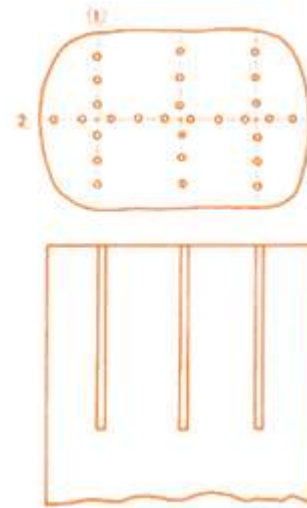

# FAQ

## FREQUENTLY ASKED QUESTIONS ABOUT CRACKAMITE

### 1. **What is the price of Crackamite?**

Crackamite is available at Rs. 50 per Kg + 3% Packing & Forwarding + GST @18% + Freight To Pay Extra at actual. Please do confirm the price with us before ordering or using. Freight charges are dependent on the type and mode of transportation as well as the destination. Payment is 100% advance against proforma invoice. You can pay by NEFT, RTGS and by cheque. You can also buy Crackamite online at The Crackamite Shop.

### 2. **How do I use Crackamite?**

You will need to have a plastic bucket, a mug (500g), a shovel, a pickaxe and a pair of gloves and eye goggles. The first step is to make holes in the stone in an appropriate pattern. Pour 1.5 liters of water in a bucket, then take a pack of 5 kg Crackamite and slowly pour it into the water and keep mixing it together, now the Crackamite is ready to use. After this Crackamite has to be filled in all the drilled holes, then it will break the stone or concrete in 8-12 hours.

### 3. **How can I calculate the quantity of Crackamite required?**

The thumb rule is 15kg required in one cubic meter.

### 4. **What transportation method are available for Crackamite?**

There are three transportation modes available for Crackamite:

- By Road (courier or truck transport)
- By Air (courier or cargo)
- By Train (courier or cargo)

### 5. **Is any certificate or license required for transportation of Crackamite?**

No, you don't require any kind of certificate or license for transit for Crackamite.

### 6. **Are you a manufacturer or trader of non-explosive demolition agents?**

Ahuja Corporation Pvt. Ltd. is a manufacturer of Crackamite not a trading company.

### 7. **Do you work as a contractor for customers?**

No, we do not do contract work with Crackamite for customers. We, however, provide on-site training for customers on chargeable basis. Please contact us through the contact form if you require training for Crackamite.

### 8. **Can you provide a demo of Crackamite at our premises?**

Yes, demonstration of Crackamite is available but on chargeable basis. Please contact us through the contact form if you require a on-site demonstration of Crackamite.

**9. Is there any Guarantee and/or Warranty for Crackamite?**

Crackamite comes with a 6 months conditional warranty applicable from the date of manufacture.

**10. What is the packaging, grade and minimum order quantity of Crackamite?**

We have only one grade of Crackamite and that is the Universal Grade. Crackamite is packed in a box of 20Kg. Each 20Kg box has 4 packets of 5Kg each. The minimum order quantity is 1 box or 20Kgs.

**11. What dispatch time for Crackamite?**

Crackamite is normally available in ready stock and shipped on the date of receipt of payment. If it is not available in ready stock, the lead time is normally 3 to 4 days to dispatch. The shipping times will vary depending on your chosen mode of transportation and destination.

# About Us

ABOUT AHUJA CORPORATION PVT. LTD.

**Customer delight is our moto**



CRACKAMITE has a dedicated team of professionals including Engineers, MBA's, ITI's and other highly committed and company trained staff, with more than 10 years' experience in this field, who provide excellent Sales & After Sales Services to our customers.

In depth knowledge of the product and its applications and a never-ending zeal to delight the customer is what keeps them going. Team CRACKAMITE constantly strives to provide customers with products of superior quality using latest technology and best of raw material.

CRACKAMITE provides the most technically suitable & cost-effective solutions for our customers. We dedicate ourselves to setting high standards for safety and service in the industry.

**Our ideas are beyond their limits**



To serve the Stone Mining, Quarrying and Construction Industry, Ahuja Corporation Private Limited (formerly Hydraulics & Pneumatics) launched CRACKAMITE - a revolutionary new demolition agent. Manufactured in a state-of-the-art facility, Crackamite has revolutionized the entire process of stone

production and demolition. We build long term relationships with our customer and change the way they do their business.

## Quality Beyond Compare

Established in 1970, Ahuja Group endeavors to build tomorrow's enterprises, optimize business and enhance end to end customer experience. We deliver quality beyond compare, to serve any customer, any channel at any time. A team of passionate, innovative, committed young minds driven by an intuitive zeal serves our very purpose of seamless – thinking and working together and outperforming competition.



## Customer Delight is Our Moto

### Our Vision:

To be the most reliable and admired brand of Silent Explosive for our customers across the world.

### Our Mission

Enabling our customers to create value and innovate by providing consistently dependable Silent Explosive and delivering an effortless procurement experience.

We believe in offering our customers unparalleled convenience, through the use of technology, offering fast delivery and a wide range of products sold at the lowest prices.

**Contact Us:**

Ahuja Corporation Pv.t Ltd.  
A-185, RIICO Prahladpura  
Industrial Area, Tonk Road,  
Jaipur 302022 INDIA

📞 +91 70233 01222

✉ support@ahujagroup.in

🌐 www.crackamite.com